

Makita Service Information / Model: FS6300

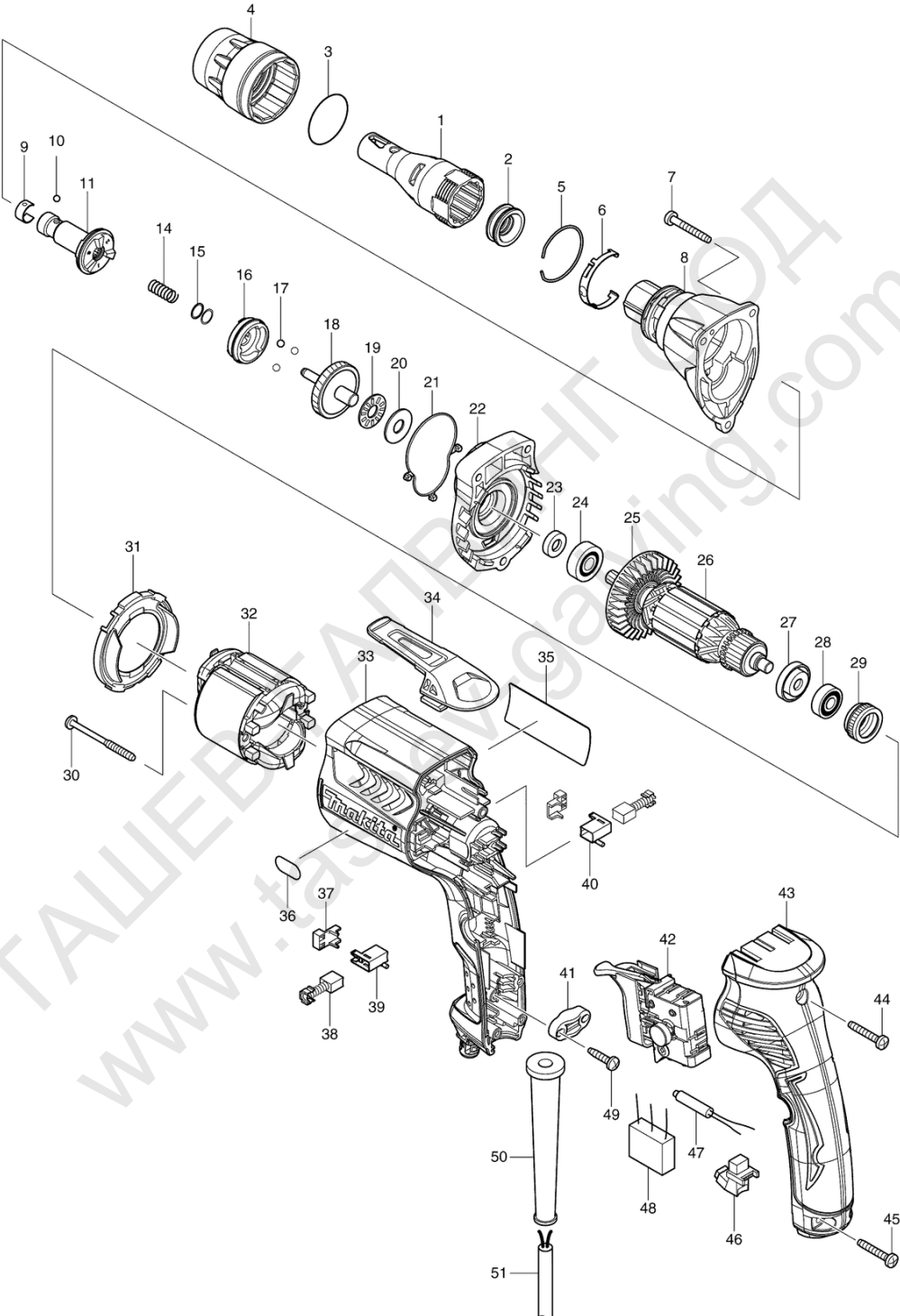

POS	Bestell-Nr.	Artikelbeschreibung	Stk.
1	158875-2	TIEFENANSCHLAG FS2300-6300	1
2	424163-2	STAUBDICHTUNGSHÜL FS2300-6300	1
3	424235-3	Dichtungsring FS2300-6300	1
4	450881-6	FIXIERRING FS2300-6300	1
5	233974-2	RINGFEDER 33 FS2300-6300	1
6	232245-4	BLATTFEDER BFS440/450	1
7	266361-0	SELBSTSCHNEID. SCHRAUBE FS2300	3
8	158881-7	GETRIEBE KPL. FS6300	1
9	232050-9	BLATTFEDER FS2300-6300	1
10	216001-0	STAHLKUGEL 3.5	1
11	158886-7	SPINDEL FS2300-6300	1
14	234121-8	DRUCKFEDER 8 FS2300-6300	1
15	267202-3	SCHEIBE 8 6823/24/25/26	2
16	223170-0	KUPPLUNG 125S FS2300-6300	1
17	216008-6	STAHLKUGEL 4 FS2300-6300	3
18	158885-9	Zahnrad kpl. FS6300	1
19	216415-3	DRUCKNADELLAGER 821 6823-26	1
20	216212-7	SCHEIBE 821 6823/24/25/26	1
21	424162-4	DICHTUNGSRING FS2300-6300	1
22	158874-4	GETRIEBEGEHÄUSED. FS2300-6300	1
23	451100-3	RING 8 FS6300	1
24	210007-0	KUGELLAGER 608VV 210007-0	1
25	240083-0	LÜFTERRAD 52 HR1830/F	1
26	515754-1	ANKER FS6300	1
26		*** INC. 23-25,27,28	
27	681636-0	ISOLIERSCHEIBE FS2300-6300	1
28	210062-2	KUGELLAGER 607ZZ MT601/952/953	1
29	421868-5	LABYRINTH-GUMMIRING 9554-95/G	1
30	266467-4	SCHRAUBE M4x50 FS2300-6300	2
31	450880-8	LUFTABLEITPLATTE FS2300-6300	1
32	633693-4	FELD 220-240V FS2300-6300	1
33	450878-5	MOTORGEHÄUSE L FS2300-6300	1
34	162272-6	EINHÄNGECLIP FS2300-6300	1
35	866558-7	FS6300 NAME PLATE	1
36	808576-9	ETIKETTE FS6300	1
37	689111-0	DISTANZPLATTE HR2020-2450/F/T	2
38	191962-4	KOHLNEN CB-419(CB-406/407)hp164	1
39	643948-9	KOHLNENHALTER DP4001/DP4003	1
40	643951-0	KOHLNENHALTER DP4001/DP4003	1
41	687124-5	KABELKLEMMPLATTE RP0900	1

POS	Bestell-Nr.	Artikelbeschreibung	Stk.
42	650614-1	SCHALTER FS2300-6300	1
43	158878-6	GRIFFSCHALE FS2300-6300	1
44	266374-1	SELBSTSCHNEID. SCHRAUBE 4x25	1
45	266374-1	SELBSTSCHNEID. SCHRAUBE 4x25	2
46	631939-2	Lichteinheit FS2300-6300	1
47	646122-8	KONDENSATOR FS2300-6300	1
48	645253-0	KONDENSATOR FS2300-6300	1
49	265995-6	SELBSTSCHN.SCHRA 4x18 BO5030	2
50	682559-5	KABELSCHUTZ 8	1
51	695034-2	KABEL 1.0-2-4.0	1
52	819349-5	ETIKETTE FS2300-6300	1
52.2	892811-5	CLEAR LABEL	1
53	423413-2	GUMMIPLATTE FS4000	1
1001	784261-7	PHILLIPS BITEINSATZ 2-25	2
1002	784811-8	BITHALTER m. MAGNET 60 mm	1